

# SMART ATTENDANCE MONITORING AND AUTO PAGING SYSTEM

CH SRINIVASA RAO<sup>1</sup> MD PARVEEN<sup>2</sup> ANITHA MURARI<sup>3</sup> RAYAPUDI BHUVANESWARI<sup>4</sup>

<sup>1</sup>ASSOC. PROFESSOR, DEPARTMENT OF ECE,

<sup>2</sup>ASST. PROFESSOR, DEPARTMENT OF ECE,

<sup>3</sup>ASST. PROFESSOR, DEPARTMENT OF ECE,

<sup>4</sup>ASST. PROFESSOR, DEPARTMENT OF ECE,

<sup>1,2,3,4</sup> SRI MITTAPALLI COLLEGE OF ENGINEERING

**Abstract:** Generally the attendance systems in schools and colleges will have an attendance register and they need to update that in the computer at the end of the month. They need to analyse the attendance for different purposes it will take a lot of time to analyse for that reason we propose a system which takes the attendance by using the fingerprint

bio-metric module in schools/colleges. By this system the verification of a student is done and the system that automates the whole process of taking attendance.

**Keywords:** Micro controller(ArduinoUno); Switches; Fingerprint Module; RTC; GSM

## 1. INTRODUCTION:

The most common means of tracking student attendance in the classroom is by enforcing the students to manually sign the attendance sheet, which is normally passed around the classroom while the lecture is conducting the lecture. There are numerous disadvantages of using such system. The attendance sheet is passed around the class; some students may accidentally or purposely sign another student's name. Another issue of having the attendance record in a hardcopy form is that a lecturer may lose the attendance sheet. As a consequence of that, a lecturer can no longer trace the students overall attendance record throughout the particular semester.

Currently, the magnetic card attendance system is widely used [1]. This pattern is flexible and practical. But it has also some disadvantages. For example, the card is easy to lost and damage. And most of all, parents are not aware if their children are absent from the class. Aiming at the disadvantages of traditional attendance system, a design method of wireless fingerprint attendance system based on GSM technology is proposed. In this system students report their attendance via biometric system and parents can receive SMS notification of attendance [2]. The fingerprint has a lot of advantages, such as unique, permanent, good anti-fake and easy to use. So it is recognized increasingly by people [3]. Figure 1 shows the general

architecture of a biometric system [4]. Biometrics systems work by recording and comparing biometric characteristics. When an individual first uses a biometric system, their identifying features are enrolled as a reference for future comparison. This reference may be stored in a central database or on a card (or both) depending on the needs of the application.

When biometric recognition is required, the individual's biometric characteristics are recorded again. This time however, the identifying features are compared by the system with the stored reference to determine if there is a close match.

## 2. SYSTEM STRUCTURE:

The system consists of fingerprint acquisition module and a GSM modem. Fingerprint acquisition module is used for capturing the fingerprint and pre-treatment. GSM modem is used to send the attendance of the students to their parents in the form of SMS.

## 3. SYSTEM HARDWARE DESIGN:

The system hardware includes: Fingerprint acquisition module, GSM modem, microcontroller, RTC, EEPROM, MAX-232, and LCD.

### 3.1 BLOCK DIAGRAM:

<https://ijgst.com.2023.v12.i2.pp174-177>

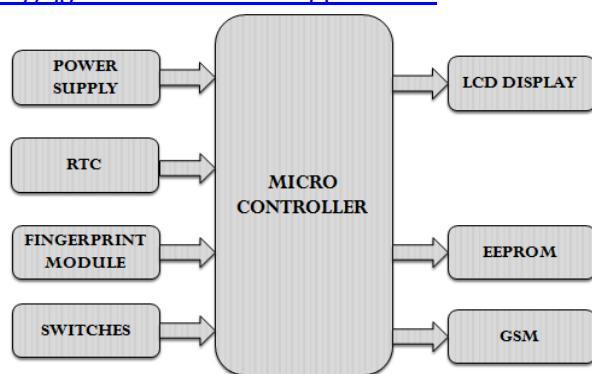

FIG 1:Block Diagram

### BLOCK DIAGRAM EXPLANATION:

This Project mainly consists of Power Supply section, Arduino Uno Microcontroller section, LCD display, temperature sensor, Buzzer, Smoke sensor, Proximity sensor, PIR Sensor, GPS, GSM, and Robot Section.

### 3.2 POWER SUPPLY:

This section is meant for supplying Power to all the sections mentioned above. It basically consists of a Transformer to step down the 230V ac to 9V ac followed by diodes. Here diodes are used to rectify the ac to dc. After rectification the obtained rippled dc is filtered using a capacitor Filter. A positive voltage regulator is used to regulate the obtained dc voltage. buzzers and beepers include alarm devices, timers and confirmation of user input such as a mouse click or keystroke.

### 3.3 RTC:

The real-time clock/calendar provides seconds, minutes, hours, day, date, month, and year information. In this we are using DS1302 chip and getting the update values of time and date. In this one we have to set the time or date that means write and every time we have to read of the update details. In this one external battery is connected to the RTC that's why its show the correct details of RTC at that time of the system will be shutdown.

### 3.4 GSM:

GSM stands for Global System for Mobile Communication and is an open, digital cellular technology used for transmitting mobile voice and data services. It uses narrow band Time Division

Multiple Access (TDMA) technique for transmitting signals [6]. TDMA is a technique in which several different calls may share the same carrier. Each call is assigned a particular time slot. A GSM modem is a specialized type of modem which accepts a SIM card, and operates over a subscription to a mobile operator, just like a mobile phone. From the mobile operator perspective, a GSM modem looks just like a mobile phone.



FIG2: Gsm Module

### 3.5 FINGERPRINT SENSOR:

The fingerprint sensor can read different fingerprints and store in its own flash memory. The sensor can perform three functions namely Add(Enroll) , Empty Database or search database and return the ID of stored fingerprint. Any of three functions can be called simply by making the pin low of the sensor or pressing onboard three switches. The response is either error or ok which is indicated by onboard LED. The response is also returned as single serial data byte. The return byte is a valid ID or error code. The response byte is a single byte at 9600 bps thus making whole sensor very easy to use. We have provide indicating LEDs and function switch already so it's ready to use when you receive it. Just give power and start using the sensor using onboard switches. Then you can move on making external application using these functions.



FIG 3: Fingerprint Sensor

<https://ijgst.com.2023.v12.i2.pp174-177>

### 3.6 ARDUINO UNO MICROCONTROLLER:

The arduino uno is an open source microcontroller board based on the microchip atmega328p microcontroller and developed by arduino. The board is equipped with sets of digital and analog input/output pins. The board has 14 digital pins, 6 analog pins, and programmable with the ARDUINO IDE via a USB cable. It can be powered by a USB cable or by an external 9 volts battery, through it accepts voltages between 7 and 20 volts.



FIG 4: Arduino Uno

### 3.7 LCD DISPLAY:

A liquid-crystal display (LCD) is a flat-panel display or other electronically modulated optical device that uses the light-modulating properties of liquid crystals. Liquid crystals do not emit light directly, instead using a backlight or reflector to produce images in color or monochrome. LCDs are available to display arbitrary images (as in a general-purpose computer display) or fixed images with low information content, which can be displayed or hidden, such as preset words, digits, and seven-segment displays, as in a digital clock. They use the same basic technology, except that arbitrary images are made up of a large number of small pixels, while other displays have larger elements. LCDs can either be normally on (positive) or off (negative), depending on the polarizer arrangement. For example, a character positive LCD with a backlight will have black lettering on a background that is the color of the backlight, and a character negative LCD will have a black background with the letters being of the same color as the backlight.



FIG 6: Lcd Display

### 4. IMPLEMENTATION:

The Arduino Uno is a microcontroller board based on ATmega328p which consists of 14 digital input output pins, 6 analog pins, USB connection, a power jack, an ICSP header and a reset button. switches are used as push up buttons. LCD displays the student details. GSM module is used to send message to parent and to the corresponding faculty. Power supply is to switch the devices. Finger print module is used to scan the person's thumb. EEPROM is used to store the finger print data. RTC (Real time clock) is used to provide minutes seconds and hours information.

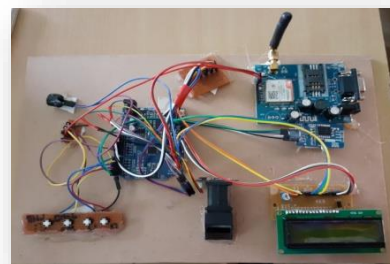
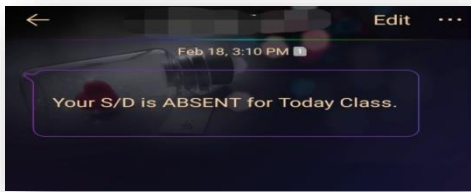

FIG 7: Fingerprint Based Attendance System

### 5. RESULT OF THE PROJECT:

The proposed system scanned the fingerprints placed on the device sensor and compared them against those stored in the database successfully. The performance of the system was acceptable and would be considered for full implementation especially because of its short execution time and reports generation. This system takes the attendance of the student and sends this attendance to their parent's mobile through GSM. Figure 6 shows the SMS received by the parents.

<https://ijgst.com.2023.v12.i2.pp174-177>



**FIG 8:** SMS Received In Parents Mobile

Reports can be easily generated in the proposed system souse can generate the report as per the requirement (monthly/weekly) or in the middle of the session. User can give the notice to the students so he/she become regular.

## 6. CONCLUSION:

The main purpose of this project is to monitor the student attendance in lecture, tutorial and laboratory sessions in more efficient way and send this attendance to their parents. This system resists students from bunking classes through SMS sending feature to parents. Biometrics has been used effectively for more than a decade for time system. Fingerprint attendance system is a cost effective simplified system that uses fingerprints for identification. The fingerprint is unique to each individual and cannot be shared.

## 7. FUTURE SCOPE:

- Student is regularly absent within four day or six days free voice call to call the parents mobile number by using GSM technology.

- The system could be modified into a web based system so that reports could be generated anywhere.

## REFERENCES

- [1] Murizah Kassim, Hasbullah Mazlan, Norliza Zaini, Muhammad Khidhir Salleh "Web-based Student Attendance System using RFID Technology" 2012 IEEE.
- [2] B. Rasagna, Prof. C. Rajendra "SSCM: A Smart System for College Maintenance" International Journal of Advanced Research in Computer Engineering & Technology, May 2012.
- [3] LI Jian-po, ZHU Xu-ning, LI Xue, ZHANG Zhi-ming "Wireless Fingerprint Attendance System Based on ZigBee Technology" 2010 IEEE.
- [4] O. Shoewu, O.A. Idowu "Development of Attendance Management System using Biometrics" The Pacific Journal of Science and Technology, May 2012.
- [5] "How does a fingerprint sensor work" Online Available: [http://wiki.answers.com/Q/How\\_does\\_a\\_fingerprint\\_sensor\\_work](http://wiki.answers.com/Q/How_does_a_fingerprint_sensor_work) [Accessed: Sept. 15, 2013].
- [6] "What is GSM?" Online Available: [http://www.tutorialspoint.com/gsm/gsm\\_overview.htm](http://www.tutorialspoint.com/gsm/gsm_overview.htm) [Accessed: Sept. 17, 2013].
- [7] L. Rajasekar, S. Vivek "Wireless Fingerprint Attendance System using Zig Bee Technology" International Journal of Power Control Signal and Computation (IJPCSC), Vol3. No1. Jan-Mar 2012.
- [8] Zatin Singhal, Rajneesh Kumar Gujral "Anytime Anywhere- Remote Monitoring of Attendance System based on RFID using GSM Network" International Journal of Computer Applications, February 2012