

## STRESS AND DEFORMATION ANALYSIS OF RC BEAM SHAVING CIRCULAR WEB OPENINGS USING FEM MODELING TECHNIQUE

NAMBI RAGHU KUMAR, THAPILA SAILEELA, BESTHA NARESH  
ASSISTANT PROFESSOR<sup>1,2,3</sup>

[raghukumar9f@svitatp.ac.in](mailto:raghukumar9f@svitatp.ac.in), [saileelaciv@svitatp.ac.in](mailto:saileelaciv@svitatp.ac.in), [bnaresh@svitatp.ac.in](mailto:bnaresh@svitatp.ac.in)

Department of Civil Engineering, Sri Venkateswara Institute of Technology,  
N.H 44, Hampapuram, Rapthadu, Anantapuramu, Andhra Pradesh 515722

### Abstract

In the event of a structure's collapse, the RC beams that make up the majority of it are the primary causes. A number of researchers are looking at RC beams to determine their strengths and weaknesses as well as ways to make them better. Various beam shapes with various types of web holes in the lateral directions are being studied in this research to determine their strength characteristics. This work makes use of both theoretical analysis and experimental examination. Rectangular forms are among the most common types of beams used. Additionally, circular web apertures are used. Using locally accessible materials, this research primarily seeks to determine the optimal strength for beam constructions. Each RC beam in this research has a load ranging from 10 kN to 150 kN. A concrete mixture's beam strength is determined by experimental testing.

**Keywords:** FEM modelling, deformation, complete strength, RC beams, rectangles, webs, and squares

### Introduction

One of the biggest issues in the building business nowadays is the degradation of concrete structures. To add insult to injury, modern standards for building safety have rendered many ancient buildings in many regions of the globe physically unsound. Strengthening has become the accepted method of enhancing the load-carrying capacity and prolonging the service life of such inadequate buildings because replacing them requires a significant investment of public funds and effort. Research has shown that fibre reinforced polymer (FRP) reinforcement may be used to replace steel reinforcement in concrete constructions, thereby avoiding the issues caused by corrosion [1]. Corrosion of reinforced concrete (RC) constructions' steel reinforcement impacts both the metal and the cement. As the steel bar's cross-sectional area decreases due to corrosion, the bar's strength decreases as well. The expansion of the corrosion products weakens the concrete's integrity, which in turn weakens the steel reinforcing bars. In the last twenty years, there have been a number of initiatives all around the globe aimed at restoring infrastructure. Steel has long been the go-to for reinforcing concrete structures like bridges and buildings. Concrete girders with bending or shear

deficiencies have been effectively repaired by externally applying bonded steel plates or stirrups [16,9]. On the other hand, steel often needs corrosion protection and adds dead load to the structure when used as a reinforcing element. Reinforcing structures using FRP is a relatively new phenomenon in the building industry; it is most often used in conjunction with other materials including concrete, steel, and wood. The non-corrosiveness, high fatigue strength, low weight-to-strength ratios, and simplicity of application are some of the appealing qualities of FRPs. Multiple studies have examined the usage of fiber-reinforced plastic (FRP) sheets and plates attached to concrete beams [14].

### Main research problems involved in this work:

1. To find the effect of loading on different shapes of beam without and with web opening for strength of beam.
2. To find the weak points of RC Beams and then try to optimize the weak points of Beams using FEM modeling techniques.

A. In very less research papers, Different type of RC beams are used so in current research study three different type of beams are used which are rectangular, T shape and I shape beams.

B. Very less research are available in web structure in lateral direction is made and then conduct research, so in present study some different type of web structure is made for selected RC beams.

### Geometrical Description of RC Beams

In present study two type of beams are selected which are rectangular beam

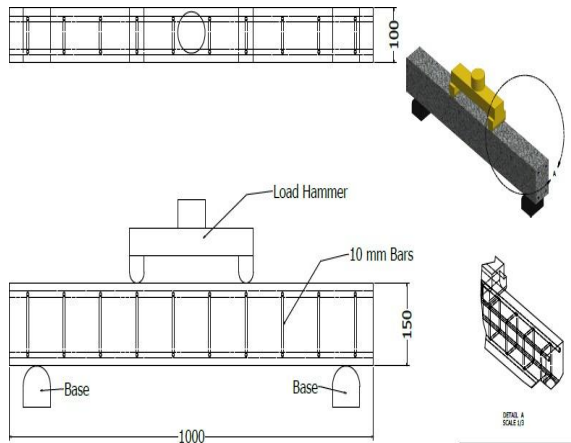

**Figure 1** RC beam of rectangular shape without web opening

This simple RC beam of rectangular shape is shown in

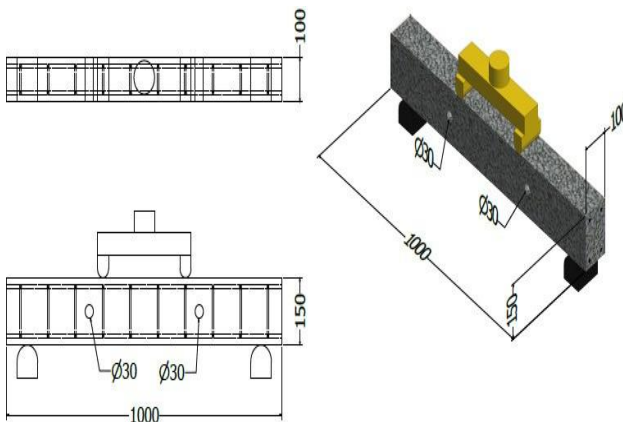

**Figure 2** RC beam of rectangular shape with circular web opening

and second is T shape beam. The beams are made with or without circular web openings and presented in figure 1 to figure 4.

Figure 1 in this beam circular web opening is not present. The dimension of beam is also presented in figure 1.

The circular web opening in rectangular beam is present in figure 2 with proper dimensions.

### Concrete Mixture and testing

In present study the beam mixture is made to find the structural

strength of beam structure which help to simulate the FEM analysis of beams, so concrete is mixed as per IS 456:2000 mixing rules and the mixing of concrete is present in table 1.

**Table 1** Beam mixing rules for present study

Description	River Sand	water	Coarse stones and	Cement
Mix Proportion (By Weight)	1.7	0.65	3.5	1

### Experiment for Block Strength Testing

The cubical block of 1 foot each length is made as per beam which we want to simulate and then experimentally measure the compression strength of concrete structure. The testing machine and block image is present in figure 3. After test on machine the maximum strength of concrete is set for 35 MPa of mixture.



(a) Strength testing machine



(b) Cubes for strength testing of concrete mixture

**Figure 3** testing of cube blocks and strength machine

**FEM modeling steps**

steps are present in table 2.

Stress and deformation analysis of beams are the main work of this study which will complete by using FEM modeling software made by Ansys. In present section the modeling steps are discussed which is used for this study. The modeling

**Table 2** Modeling steps of FEM simulation

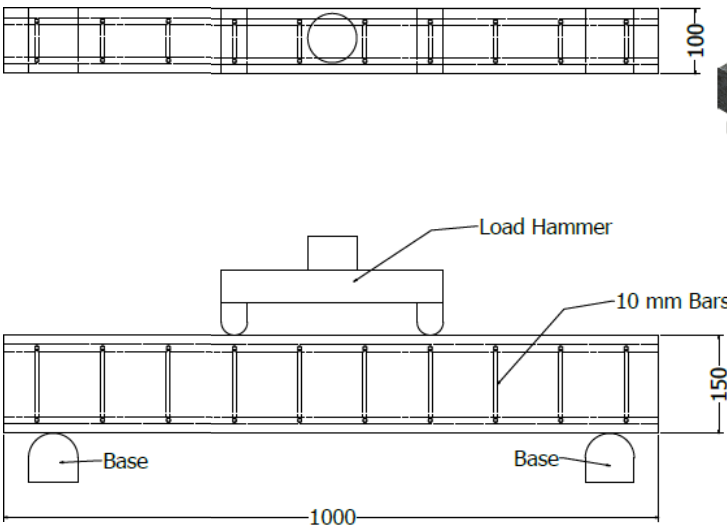
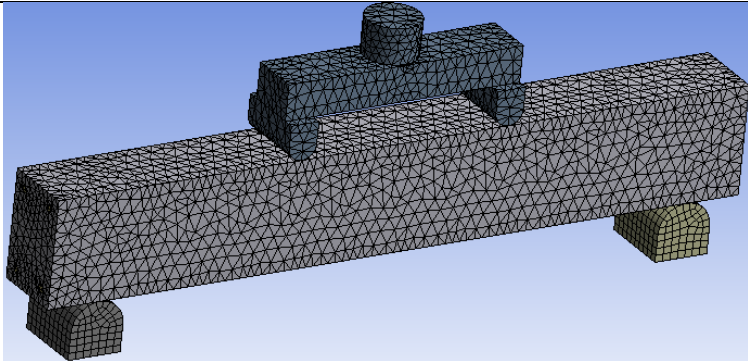
Steps	Image	Description
I: CAD Generation		Autodesk Inventor software is used for CAD file generation
II: Mesh Generation		Total Element = 119451
III: Material Selection	Concrete, Structural Steel	Properties in figure 7 and figure 8

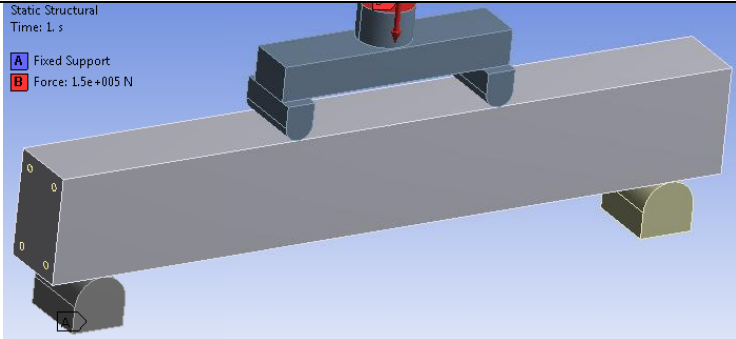
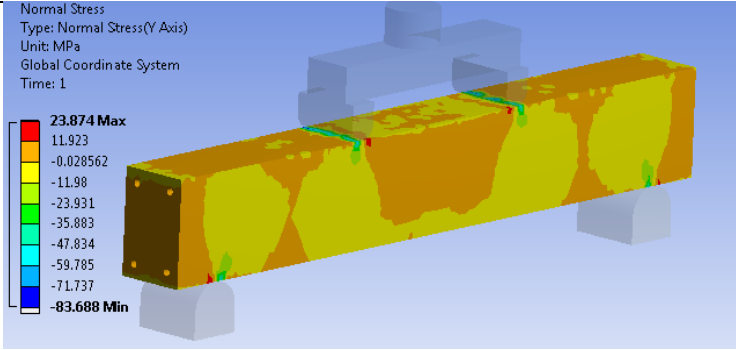
Steps	Image	Description																										
<p>IV: Boundary Conditions</p>		<p>Cylindrical support present bearing effect</p>																										
<p>V: Analysis Settings</p>	<p>APDL rules for structural modeling</p>	<p>Large Deformation is ON</p>																										
<p>VI: Solver</p>	<table border="1" data-bbox="516 947 1057 1388"> <tr> <td colspan="2"><input type="checkbox"/> <b>Solution Information</b></td> </tr> <tr> <td>Solution Output</td> <td>Solver Output</td> </tr> <tr> <td>Newton-Raphson Residuals</td> <td>0</td> </tr> <tr> <td>Update Interval</td> <td>2.5 s</td> </tr> <tr> <td>Display Points</td> <td>All</td> </tr> <tr> <td colspan="2"><input type="checkbox"/> <b>FE Connection Visibility</b></td> </tr> <tr> <td>Activate Visibility</td> <td>Yes</td> </tr> <tr> <td>Display</td> <td>All FE Connectors</td> </tr> <tr> <td>Draw Connections Attached To</td> <td>All Nodes</td> </tr> <tr> <td>Line Color</td> <td>Connection Type</td> </tr> <tr> <td>Visible on Results</td> <td>No</td> </tr> <tr> <td>Line Thickness</td> <td>Single</td> </tr> <tr> <td>Display Type</td> <td>Lines</td> </tr> </table>	<input type="checkbox"/> <b>Solution Information</b>		Solution Output	Solver Output	Newton-Raphson Residuals	0	Update Interval	2.5 s	Display Points	All	<input type="checkbox"/> <b>FE Connection Visibility</b>		Activate Visibility	Yes	Display	All FE Connectors	Draw Connections Attached To	All Nodes	Line Color	Connection Type	Visible on Results	No	Line Thickness	Single	Display Type	Lines	<p>APDL Solver</p>
<input type="checkbox"/> <b>Solution Information</b>																												
Solution Output	Solver Output																											
Newton-Raphson Residuals	0																											
Update Interval	2.5 s																											
Display Points	All																											
<input type="checkbox"/> <b>FE Connection Visibility</b>																												
Activate Visibility	Yes																											
Display	All FE Connectors																											
Draw Connections Attached To	All Nodes																											
Line Color	Connection Type																											
Visible on Results	No																											
Line Thickness	Single																											
Display Type	Lines																											
<p>VII: PostProcessing</p>		<p>Deformation, Stress</p>																										

In Ansys FEM software mesh will be checked by using mesh metric command and the element quality of mesh is present in figure 4 for rectangular block.

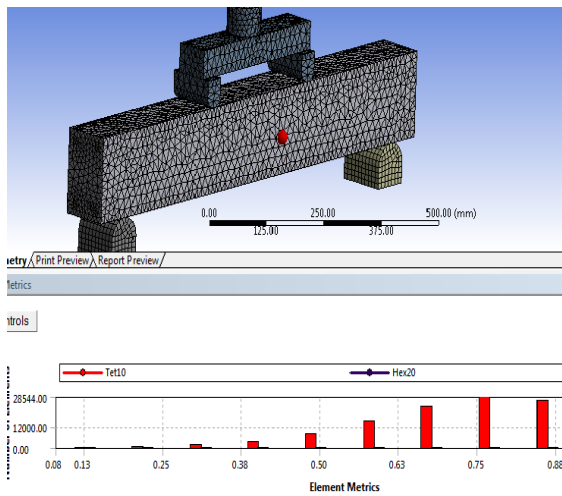

**Figure 4** Element Quality of Discretized Domain

### Material Properties

In FEM simulation proper material properties required for better analysis, so in this section the material properties for concrete and structural steel is present in figure 5 and figure 6. The material properties are selected from literature available in digital media and research papers.

Property	Value	Unit
Density	2300	kg m <sup>-3</sup>
Isotropic Secant Coefficient of Thermal Expansion		
Isotropic Elasticity		
Derive from	Young's Modu...	
Young's Modulus	3E+10	Pa
Poisson's Ratio	0.18	
Bulk Modulus	1.5625E+10	Pa
Shear Modulus	1.2712E+10	Pa
Tensile Yield Strength	0	Pa
Compressive Yield Strength	9	MPa
Tensile Ultimate Strength	5	MPa
Compressive Ultimate Strength	41	MPa

**Figure 5** material properties of concrete used for FEM simulation

Property	Value	Unit
Material Field Variables	Table	
Density	7850	kg m <sup>-3</sup>
Isotropic Secant Coefficient of Thermal Expansion		
Isotropic Elasticity		
Derive from	Young's Modu...	
Young's Modulus	2E+11	Pa
Poisson's Ratio	0.3	
Bulk Modulus	1.6667E+11	Pa
Shear Modulus	7.6923E+10	Pa
Alternating Stress Mean Stress	Tabular	
Strain-Life Parameters		
Tensile Yield Strength	2.5E+08	Pa
Compressive Yield Strength	2.5E+08	Pa
Tensile Ultimate Strength	4.6E+08	Pa
Compressive Ultimate Strength	0	Pa

**Figure 6** material properties of structural steel used for FEM simulation

**Result and Discussion**

In order to determine the impact of stress and deformation on concrete and steel bar blocks, this research statistically investigates rectangular beams with and without circular web holes. For deformation, the investigation is mostly conducted.

as well as the standard examination of a rectangular beam with or without a

hollow web. The analysis of these results is presented and discussed in depth in the next section.

Table 3 contains the full data, and Figure 7 shows the graphical depiction of normal stress in force direction. The primary finding of this research is shown in figure 7, which shows that the beam is affected by normal stress in both positive and negative directions.

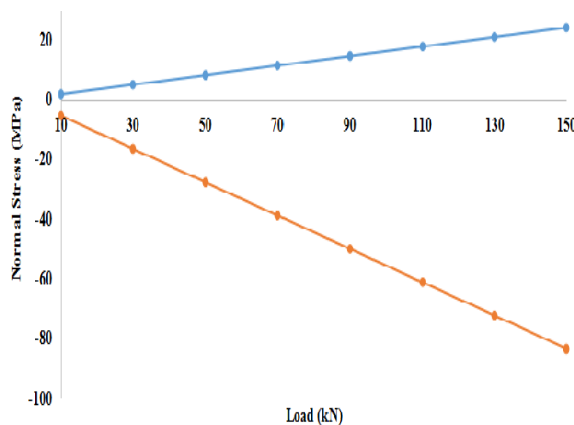

**Figure 7** Stress and Load for Rectangular Beam without Circular web

The stress in negative direction is much higher than stress in positive direction which

indicate that the beam is mainly facing the compression stress in its structure. Although the figure 7 is not the only figure which tells the failure of beams, more detailed analysis is also required for finding the failure of beam.

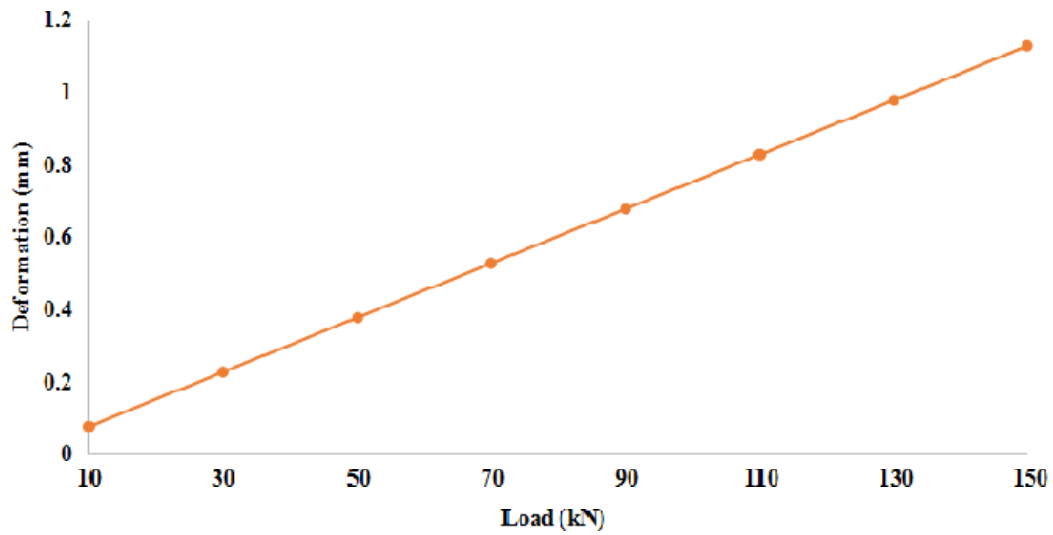

**Figure 8** Deformation and Load for Rectangular Beam without Circular web

The deformation of beam for without circular web opening is present in figure 8 and the detailed results are present in table 4 for both type of design of beam. The profile is linear for this beam geometry.

**Table 3** Normal Stress comparison among with and without circular rarring

<b>Load</b>	<b>Rect-NS(-)</b>	<b>Rect-NS(+)</b>	<b>Rect-O-NS(-)</b>	<b>Rect-O-NS(+)</b>
<b>kN</b>	<b>MPa</b>	<b>MPa</b>	<b>MPa</b>	<b>MPa</b>
10	-5.58	1.59	-5.58	1.58
30	-16.74	4.77	-16.75	4.73
50	-27.90	7.96	-27.92	7.88
70	-39.05	11.14	-39.09	11.03
90	-50.21	14.32	-50.25	14.19
110	-61.37	17.51	-61.42	17.34
130	-72.53	20.69	-72.59	20.49
150	-83.69	23.87	-83.75	23.64

**Table 4** Deformation analysis for Rectangular beam with and without circular web opening

<b>Load</b>	<b>Deformation-Rect</b>	<b>Deformation-Rect-O</b>
<b>kN</b>	<b>mm</b>	<b>mm</b>
10	0.075	0.076
30	0.226	0.228
50	0.376	0.380

70	0.526	0.533
90	0.677	0.685
110	0.827	0.837
130	0.977	0.989
150	1.128	1.141

In table 3 and table 4 the normal stress and deformation of rectangular beam is present for 10 kN loading to 150 kN loading on impactor of load. The best part of FEM simulation is visual analysis of beam which actually give proper

investigation part of different loading. And the results are present in table 5 for normal stress in loading direction (y-direction). As seen in table there is huge change in stress profile by using circular web opening.

**Table 5** Normal Stress analysis for Rectangular beam with and without circular web opening

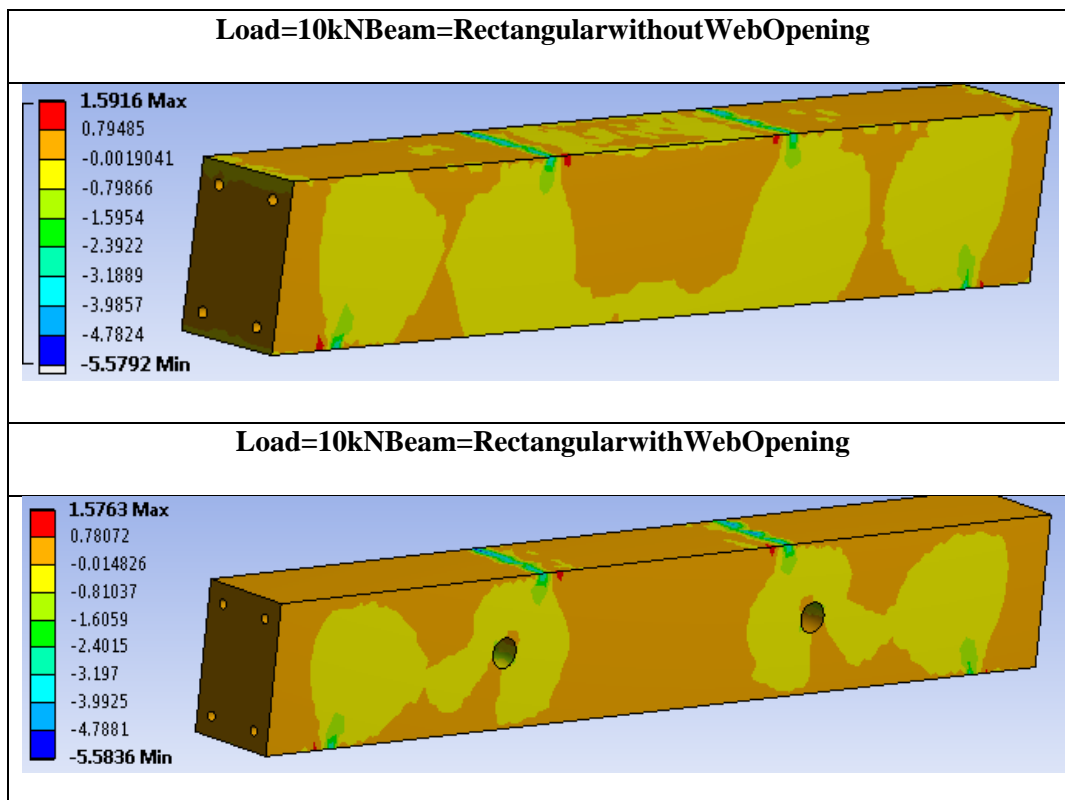

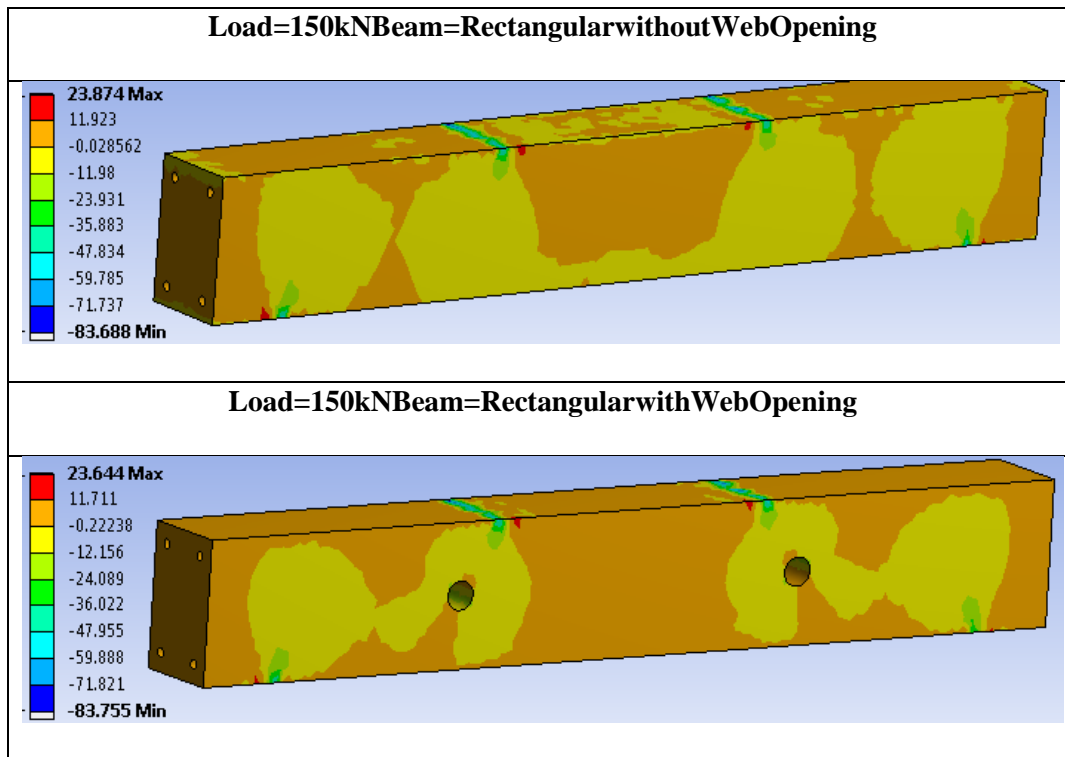

## Conclusion

In this study rectangular beam which has circular web opening is investigated using FEM simulation software made by Ansys. The loading is set from 10 kN to 150 kN for this beam structure. The main conclusion from study are following:

A. Normal stress and deformation analysis for 10 kN to 150 kN is performed and the profile for both type of parameters are linear till this loading system. The reason is the materials properties selection which can be the main reason behind this profile of stress and defor-

mation.

B. By visual analysis of stress it is clear that by providing the circular web opening can distribute the stress when compare with simple rectangular beam, so proper web openings can increase the stress relieving capacity of beam.

### References

Abed F et al., FE modeling of concrete beams and columns reinforced with FRP composites, Defence Using Ansys's finite element modelling (FEM) software, this research examines a rectangular beam with a circular web opening. This beam construction has a loading range of 10 kN to 150 kN. Here are the key findings from the study:

A. Up to this loading system, the profiles for both types of parameters are linear, and a study of normal stress and deformation is carried out from 10 kN to 150 kN. This stress-deformation profile may have its roots in the materials' chosen characteristics.

B. A visual examination of stress clearly shows that, in comparison to a plain rectangular beam, a circular web opening may better disperse the stress, therefore, the correct web openings can enhance the beam's ability to relieve stress.

[1] ,<https://doi.org/10.1016/j.dt.2020.02.015>

[2] Kowalski R., Urbański M. On the Redistribution of bending moments in two-span RC beams and slab exposed to fire. *J Civ Eng Archit* 2013;7(2):158–73. David Publishing Company (ISSN 1934-7359; print, 1934-7367 online). DOI:10.17265/1934-7359/2013.02.006.

[3] Mindeguja C, Hager I, Pimienta P, Carre H, La Borderie C. Parametrical study of transient thermal strain of ordinary and high performance concrete. *Cem Concr Res* 2013;48:40–52. <https://doi.org/10.1016/j.cemconre>

s.2013.02.004.

[4] Anderberg Y. Fire-exposed hyperstatic concrete structures - an experimental and theoretical study. *Bulletin of Division of Structural Mechanics and Concrete Construction*, Bulletin 55, Lund (Sweden); 1976.

[5] Anderberg Y, Thelandersson S. Stress and deformation characteristics of concrete at high temperatures. 2. Experimental investigation and material behaviour model. *Bulletin of Division of Structural Mechanics and Concrete Construction*, Bulletin 54, Lund (Sweden); 1976.

[6] Gernay T, Franssen JM. A formulation of the Eurocode 2 concrete model at elevated temperature that includes an explicit term for transient creep. *Fire Saf J* 2012; 51:1–9. <https://doi.org/10.1016/j.firesaf.2012.02.001>.

[7] Chudzik P, Kowalski R, Abramowicz M. Strains of concrete in RC structures subjected to fire. *Procedia Eng* 2017;193:377–84. <https://doi.org/10.1016/j.proeng.2017.06.227>.