

ECO-FRIENDLY ROAD CLEANER

VENNAPUSA VENKATA SIVA REDDY, VARDIREDDY VISWESWARA REDDY, KALLA PARTHASARATHI REDDY

ASSOCIATE PROFESSOR¹ ASSOCIATE PROFESSOR² ASSISTANT PROFESSOR³

sivareddy.vennapusa1@gmail.com, vvrindustries@gmail.com, kpsreddy999@gmail.com

Department of Mechanical Engineering, Sri Venkateswara Institute of Technology,
N.H 44, Hampapuram, Rappthadu, Anantapuramu, Andhra Pradesh 515722

ABSTRACT: Uncleanliness and accident concerns are caused by dirt other than the road, according to our analysis. We had created a machine that could clean the sides of roads semi-automatically. Every single one of us has an innate urge to keep our living spaces clean, and doing so is an integral part of our regular routine. In many places, such roads, railways, airports, hospitals, bus stands, and stations, the traditional road and floor cleaning equipment is employed. Our idea aims to use affordable, user- and control-friendly, level material. Conventional machining may be improved using this alternative. When compared to machines, an environmentally friendly road cleaning equipment that is run manually can clean more area in less time at a lower cost. Plus, it's cheap. It is both environmentally friendly and easy to use. The roller brush of this road cleaner is powered by a chain drive system and spur gear. One of the innovative, user-friendly characteristics of this road cleaning equipment is the ability to modify the roller brush's contact with the floor to suit different cleaning tasks. If you need to clean the roadside area around the divider more thoroughly, you may lower the roller a little and use a scrubber.

Keywords: Equipment such as scrubbers, roller brushes, spur gears, adjusters, and so on

INTRODUCTION:

Every living thing, from humans to apes, has an environment. That's why it's crucial to maintain it clean. Because polluted air brings terrible society, illness outbreaks, and other problems, we could all use some fresh air, and we certainly wish to see pollution levels reduced. Improving the nation's cleanliness has been a priority for a while now. In terms of efficacy and applicability, there is no silver bullet. The cleaning method, the equipment, and the kind of cleaning device all have a role in how well something is cleaned. Cleaning is a physically hard job, and there has to be a system in place to evaluate new products ergonomically. Due to a shortage of workers, floor and road cleaning robots have become more popular in recent years, especially among elderly and busy people. A less labor-intensive cleaning equipment is necessary, however, since unemployment is higher in India.



FUNCTION OF ROAD CLEANING MACHINE:

Function of road cleaning machine are mainly

- Remove the dust from road by the use of roller brush.
- Cleaning of dust and dirt by use of brush.
- Collecting the dust into collector tank.

PROBLEM STATEMENT:

It takes more time and the workers can't work continuously if they clean the road with super, therefore we need to think of additional ways to make it easier. The machine's cheap operating costs and the money saved on worker salaries more than offset the cost of installation, which is a major consideration in reducing traffic problems and accidents. Within an hour to a year and a half, it may be restored. When using an environmentally friendly road cleaning equipment, the rubbing action between the road and the roller brush is the second most



common issue. Our roller brush adjuster allows you to fine-tune your brushing technique to eliminate these issues.

MAIN OBJECTIVE OF THE PRESENT WORK:

To provide a different way of cleaning the streets, to save time, and to lessen the workload on humans.

COMPONENTS:

Scrubber: Scrubber is an important component of our cleaning machine and it is also connected to the soft and it is connected to a bevel gear which acts at a 90 degree. When soft starts rotate then it also starts to rotate.

Brush: The cleaning brush is located in between the wheels which are rotating. It is connected by the chain drive system. When wheels are rotate then it also start to rotate. It is made of polymer plastic. It is little hard plastic

Chain drive: It is made up of rigid links which are hinged together. Main function of chain drive is to transfer the power from one shaft to another shaft. It provides the

necessary flexibility for wrapping around the driving and driven wheel.

flexibility of the driving and driven wheel.

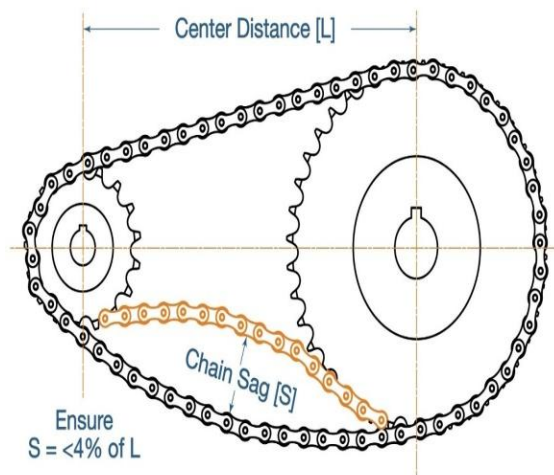

Fig.03 (Chain drives)

www.baartgroup.com

Gear: Gear pair is used to increase or reduce the speed of the shaft. It consists of two cylindrical gears with projecting teeth. There are various

types of gears available in the market but spur gear is the most commonly used type of gear.



Fig.04 (Spur gear)

www.motioncontroltips.com

IMPORTANT DIMENSION OF THE ROAD CLEANING MACHINE:

In this work there are various components which are reused as the following way

Wheels: There are two wheels are used having dimension of 630 mm as shown in figure. **Shaft:** The soft length is 750 mm and its diameter is 25 mm.

Chain: Total chain length which are used in 850 mm of 75 number. **Supporting wheel:**

Diameter of wheel is 200 mm.

Handle: In our project we used a suitable handle which are beneficial and comfortable. According to the workers it is neither small nor long.

Gears: Used two pairs of wires and smaller gear diameter is 26 mm and larger gear diameter is 85 mm.

Brush: Brush having length of 500 mm long and circular dia of 250 mm and rod diameter is 20 mm. **Collecting box:**

The function of collecting box used to collect the waste up to some quantity after that remove box and dump the waste.

Adjustments: There are adjuster which is used to separate the contact between roller brush and ground. It is most important factor.

WORKING PRINCIPLE OF ROAD CLEANING MACHINE:

Road cleaning machine is a type of eco-friendly machine because in operation of this machine there is no requirement of any types of fuel by which it can produce

harmful gases. We can say that it is an eco-friendly road cleaning machine because by using this machine, not require of any types of fuel and it is a pollution free device and major advantage is that we are not removing the employment. It is human operated road cleaning machine and only human power is required when any person employs pushes the machine then it moves forward and by which wheels are rotated and on the wheel soft chain driver is to be mounted and it also starts the rotating and now it is also have a free wheel which is placed half some distance and both are connected by the chain and as well as start rotating it also starts to move and it rotates the roller brush now then it tries to throw the dust particle into dust collector chamber.

ROAD CLEANING MACHINE:

The road cleaning machine is operated by the human and it uses two rods which are connected to the front of the shaft. When we applied force on the handles, it exerts a force on wheel by which wheel will rotate and moves forward. This road cleaning machine also useful to clean floor and street. It is a big advantage of this machine. It can be easily used for multipurpose work. This machine can easily move backward and forward. In this we find that when an employee moves this machine then if roller and road contact is much more than rubbing action will occur by which roller brush can be damaged that's why to reduce this problem we will provide the head adjuster and by using this employee can set the roller according to his own convenience.

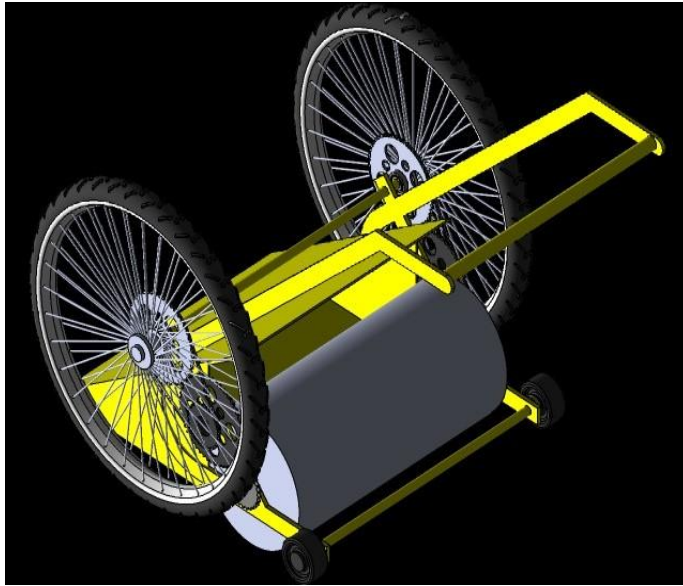

Fig.05(Road cleaning machine) www.grabcad.com

CONCLUSION:

The road and floor cleaner that is operated manually has been created and manufactured with success. In order to clean the roads more efficiently and with less human labour, this initiative is using a manually driven environmentally friendly road cleaner. In the event of a power outage, it is the most effective substitute for an automatic road cleaning system. A road cleaning equipment can be operated with the minimum amount of human labour. Manual Debris removal leads to shoulder discomfort as a result of ongoing sweeping, it is necessary to develop such a machine that simplifies the task and cuts down on time.

REFERENCES:

ISSN: 2321-9653; IC Value: 45.98; SJ Impact Factor: 6.887; the International Journal of Research in Applied Science and Engineering Technology (IJRASET). Visit www.ijraset.com to access Volume 6, Issue V, published in May 2018. MODAK J. P. "Bicycle Drive Mechanism & its Adoption to the Development of a Manually Energised Process Machine" was an invited lecture given at the National Seminar on Human Engineering in January 1995, which was organised

by VIT, Pune & IIIE Chapter, Pune. "Design and Development of Manually Energised Process Machines having relevance to Village/Agriculture and other Productive Operations" has been written by J. P. Modak. A global organisation focused on human potential. The machine element that V. B. Bhandari designed. Investigation of the study article "International Research Journal of Engineering and Technology, ISSN: 2395:0056" about the development of a road cleaning machine
Abstract: "Design of dust collector for rear wheel of four-wheeler" by Abhishek Chakraborty and Ashutosh Bansal was published in July 2013 in the International Journal of Emerging Technology and Advanced Engineering (ISSN 2250-2459), which is an ISO 9001:2008 Certified Journal. examination of the roller chain drive system using the dynamic approach of multiflexible bodies. R.K. Bansal's analysis on the loading on the shaft. An examination of gear configurations by S. S. Rattan (Mc Graw Hill). Designing the gear for a milling machine analytically is a part of production engineering. Volume 6, Issue 9, pages 32–35, October 26, 2017, Research Journal of Engineering Science. Milling machine study and performance.